

A
Bray
High
Performance
Company

Flow-Tek

A Subsidiary of BRAY INTERNATIONAL, Inc.

INSTALLATION - MAINTENANCE MANUAL

Full Port, 2 PC Ball Valve S85

1. USE:

Maximum results and long life of the valve can be maintained under normal working conditions and in accordance with Flow-Tek's pressure/temperature and corrosion data. During shipment, storage, and in operation, the valve should be fully open or fully closed ("open" is preferred for shipping and storage). Do not use in intermediate positions without knowledge of flow and pressure drop.

2. MANUAL OPERATION:

The opening and closing of the valve is done by turning the handle a 1/4 turn (90 degree turn).

A. VALVE OPEN POSITION

The handle is in line with the valve or pipeline.

B. VALVE IN CLOSED POSITION

The handle is across the pipeline.

Valves with actuators should be checked for actuator - valve alignment. Angular or linear misalignment will result in high operational torque, and damage to valve stem and seals.

3. STEM SEAL ADJUSTMENT

If slight leakage is noted at stem, straighten lock washer tab, tighten stem nut to flatten Bellville Washers, back stem nut off 1/4 turn, secure lock washer tab.

4. DISASSEMBLY AND CLEANING PROCEDURE:

- 4.1 If the valve has been used to control hazardous media, it must be decontaminated before disassembly. It is recommended that the following steps be taken for safe removal and assembly.
- 4.2 As shipped from the factory, Valves contain Silicone based lubricant. This is for break-in and may be removed by disassembly and solvent washing, if it is objectionable for a particular application.

5. GENERAL INFORMATION FOR ON-SITE INSTALLATION:

- 5.1 The valve may be fitted in any position on the pipeline.
- 5.2 Before installing the valves, the pipes must be flushed clean of dirt, burrs, and welding residues, or the seats and ball surface will be damaged.
- 5.3 The pipe must be free of tension.

6. INSTALLATION:

- 6.1 Use conventional sealant, such as hemp core, Teflon, etc..
- 6.2 Apply wrench only on the hexagon valve end being tightened. Tightening by using the valve body or handle can seriously damage the valve.

7. DISASSEMBLY FOR STEM AND SEAL REMOVAL:

CAUTION: Ball valves can trap pressurized media when closed. Flush line with valve 1/2 open to remove hazardous media.

Stem seal leakage may be corrected without disassembly by tightening the packing sleeve nut (the nut underneath the handle) until such leakage stops. If the leakage continues or valve operating torque becomes excessive, the seals are worn and replacement will be necessary.

- A. Remove valve from line for servicing.
- B. Loosen handle nut and remove handle. Remove packing sleeve nut.
- C. Remove the threaded end cap for disassembly, leaving the ball for last.
- D. EXTREME CARE should be taken upon ball removal as not to scratch seating surface or the stem, which will result in leakage after reassembly.
- E. Remove all seats, seals, stem packing and thrust washer.

8. ASSEMBLY:

- 8.1 Install the thrust washer on stem O.D.
- 8.2 Install stem packing in valve body.
- 8.3 Insert stem into body, taking care not to pinch or nick stem packing.
- 8.4 Install seat in the rear of the body cavity with the spherical curvature facing the mating ball.
- 8.5 Insert ball in body, care should be taken not to scratch the ball during installation.
- 8.6 Insert seat in threaded end cap so that spherical curvature is facing the ball. Tighten end cap tightly.
- 8.7 Tighten packing sleeve nut.
- 8.8 Place handle on assembly and tighten stem nut.
- 8.9 Safe and proper bench testing is required before re-installing to service. Ensure that valve operates smoothly.

Warning: DO NOT REMOVE ANY VALVE PARTS WHILE LINE IS UNDER PRESSURE! UNDER NO CIRCUMSTANCES! LINE MUST BE DEPRESSURIZED BEFORE DISASSEMBLY. VALVE SHOULD BE CYCLE TO ASSURE THERE IS NOT PRESSURE IN VALVE CAVITY.

PART LIST:

ITEM	NAME
1	BODY
2	END CAP
3	BALL
4	SEAT #
5	STEM
6	BODY SEAL #
10	ANTI-STATIC
11A/B	THRUST BEARING #
12	THRUST WASHER #
14	STEM PACKING #
15	PACKING GLAND
18	BELLEVILLE WASHER
19	LOCK WASHER
23	STOP SET SLEEVE
24	STOP BOLT
25	HANDLE
26	THIN NUT
28	HANDLE SLEEVE
29	LOCKING DEVICE

Parts included in the repair kits

VALVE COMPONENTS:

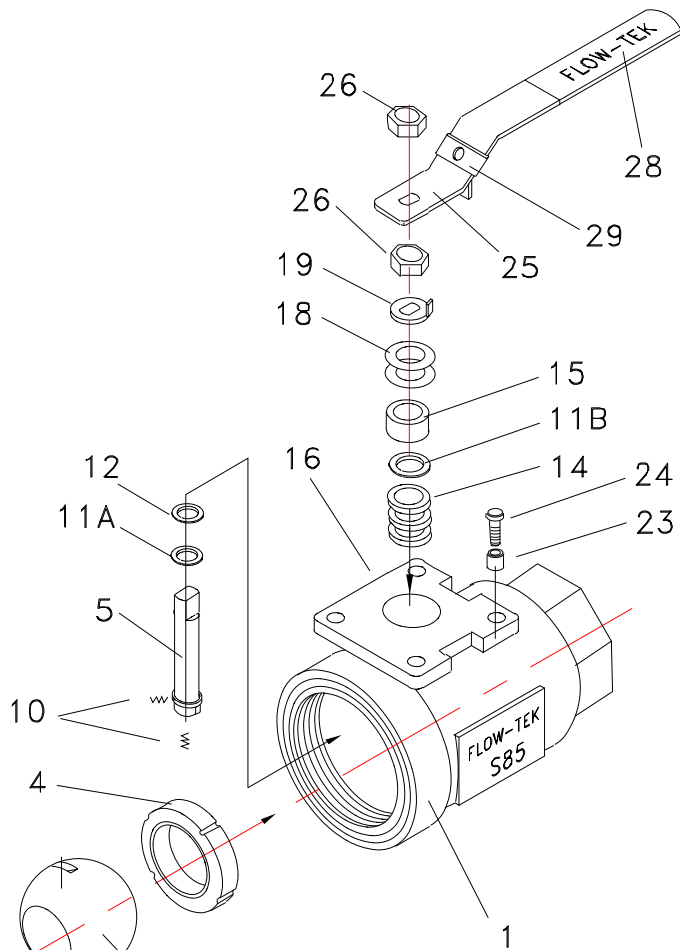
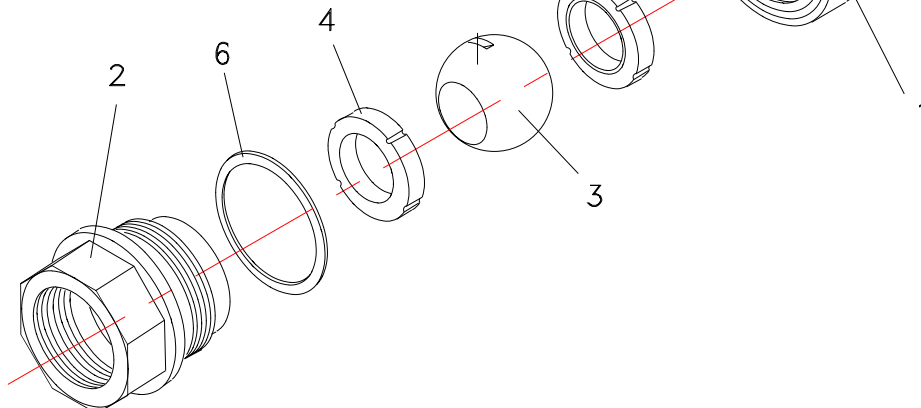

This brochure is general in nature and manufacturer reserves the right to alter dimensions, materials or to make design improvements