

Bray Series 63-N4/N7 Installation & Maintenance Instructions

General Purpose/Rain tight/Water tight and
Rain tight/Water tight/Explosion proof

For S63-N4 see O&M Instructions for information on: Operation, Positioning, Mounting, Cleaning, Preventive Maintenance, Causes of Improper Operation, Disassembly, and Reassembly of basic valve.

DESCRIPTION

S63 N4/N7 Solenoid coils are thermoplastic encapsulated pull-type for use with Bray solenoids. These solenoids have three lead wires with one wire for grounding and a ½ NPT male conduit connection. S63 N4 Solenoids are designed to meet Enclosure Type 1-General Purpose, Types 3 and 3S-Raintight, and Types 4 and 4X-Watertight. S63 N4/N7 Solenoids meet Enclosure Types 3 and 3S-Raintight, Types 4 and 4X-Watertight, Type 7 Explosion proof Class I, Division 1, Groups A, B, C, & D and Type 9 - Dust - Ignition proof Class II, Division 1, Groups E, F, & G.

OPERATION

When the solenoid is energized, the core assembly is drawn into the plugnut/core tube sub-assembly. When the solenoid is de-energized, spring force returns the core assembly to the original position.

Enclosure Types 7 and 9 Only



CAUTION

To prevent fire or explosion, do not install solenoid and/or valve where ignition temperature of hazardous atmosphere is less than 160° C. Open circuit before disassembling.

Positioning

Solenoid may be mounted in any position.

Valve Mounting

The solenoid is assembled onto an actuator and is rigidly supported using the actuator body mounting provisions.



CAUTION

Solenoid coil wiring must be carried out by trained personnel.

Wiring

Wiring must comply with local codes and the National Electrical Code. The solenoid is provided with lead wires and one grounding wire, which is green or green with a yellow stripe. To facilitate wiring, the solenoid may be rotated 360° in 90° increments. To rotate solenoid, remove the four mounting screws, reposition solenoid and replace screws. Torque screws evenly in a criss-cross manner to 12 in-lbs [1.3 Nm].

Solenoids have a ½-14 NPT male thread. For connection to rigid metal conduit, metal type NPT electrical fittings should be used.



WARNING

For the watertight and explosion proof solenoid, electrical fittings must be approved for use in hazardous locations.

All information herein is proprietary and confidential and may not be copied or reproduced without the expressed written consent of BRAY INTERNATIONAL, Inc.

The technical data herein is for general information only. Product suitability should be based solely upon customer's detailed knowledge and experience with their application.



CAUTION

Temperature of external casing of coil can burn skin.

Solenoid Temperature

Standard solenoids are designed for continuous duty service. When the solenoid is energized for a long period, the solenoid becomes hot and can be touched by hand only for an instant. This is a safe operating temperature.

MAINTENANCE



WARNING

To prevent the possibility of personal injury or property damage, turn off electrical power, depressurize valve, and vent medium to a safe area before servicing.

Cleaning

All solenoid valves should be cleaned periodically. The time between cleaning will vary depending on medium and service conditions. In general, if the voltage to the solenoid is correct, sluggish valve operation, excessive noise, or leakage will indicate that cleaning is required. In the extreme case, faulty valve operation will occur and the valve may fail to shift. Clean strainer or filter when cleaning the valve.

Preventive Maintenance

- Keep the medium flowing through the solenoid valve as free from dirt and foreign material as possible.
- While in service, the solenoid valve should be operated at least once a month to ensure proper opening and closing.
- Depending on the medium and service con-

ditions, periodic inspection of internal valve parts for damage or excessive wear is recommended. Thoroughly clean all parts. Replace any worn or damaged parts.

Causes of Improper Operation

- **Faulty Control Circuit:** Check the electrical system by energizing the solenoid. A metallic click signifies that the solenoid is operating. Absence of the click indicates loss of power supply. Check for loose or blown fuses, open-circuited or grounded solenoid, broken lead wires or splice connections.
- **Burned-Out Solenoid:** Check for open-circuited solenoid. Check supply voltage; it must be the same as specified on nameplate and marked on the solenoid. Check ambient temperature and check that the core is not jammed. If necessary, replace pilot valve.
- **Low Voltage:** Check voltage across the solenoid leads. Voltage must be at least 85% of rated voltage.

ORDERING INFORMATION FOR REPLACEMENT PILOT VALVE WITH SOLENOID:

1. Specify valve Catalog Number
2. Solenoid Catalog Number
3. Serial Number
4. Voltage
5. Frequency

All information herein is proprietary and confidential and may not be copied or reproduced without the expressed written consent of BRAY INTERNATIONAL, Inc.

The technical data herein is for general information only. Product suitability should be based solely upon customer's detailed knowledge and experience with their application.

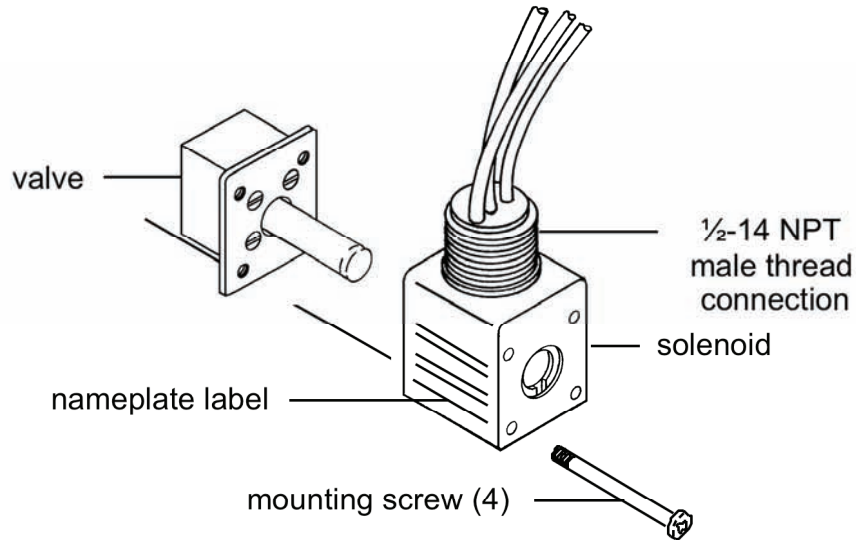

Figure 1. S63-N4 General Purpose/Raintight/Watertight Solenoid.

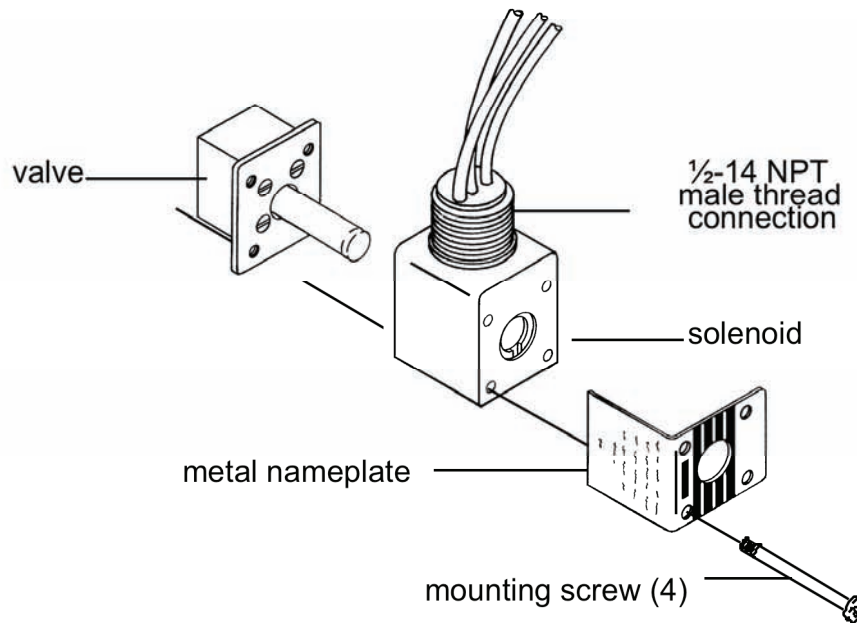

Figure 2. S63-N4/N7 Raintight/Watertight/Explosionproof Solenoid.

All information herein is proprietary and confidential and may not be copied or reproduced without the expressed written consent of BRAY INTERNATIONAL, Inc.

The technical data herein is for general information only. Product suitability should be based solely upon customer's detailed knowledge and experience with their application.