



A Subsidiary of Bray International, Inc.

TRIAD SERIES BALL VALVES

(FP2000/FP3000 SP2000/SP3000)

INSTALLATION - MAINTENANCE MANUAL

DESIGN

The design features of this valve include a three piece construction, allowing ease of maintenance without special tools. These valves feature a "free floating" ball. The ball is not fixed, but is free to move with the line pressure. As a result of this feature, these valves are capable of tight shut-off with flow in either direction regardless of the position of the valve in the line.

The downstream seat, opposite the pressurized side of a closed valve, must carry the load exerted by the line pressure on the ball, while the upstream seat is subject to little load or wear. Turning the valve end-for-end in the pipeline will increase useful seat life by dividing seat wear between the two seats.

1. USE:

The valve should be maintained as part of a preventative maintenance program and in accordance with Flow-Tek's recommended pressure, temperature and corrosion limits to ensure a long service life. During shipment, storage, and in operation, the valve should be fully open or fully closed ("open" is preferred for shipping and storage). Do not use in throttling service without investigating flow and pressure conditions.

WARNING: Before installing this equipment, confirm that it is suitable for the intended service.

The identifications tags describe the maximum allowable service conditions for this product.

Be sure that the installation is protected by appropriate pressure control and safety devices to ensure that acceptable limits are not exceeded.

2. OPERATION:

Operation of the valve is done by turning the handle a 1/4 turn (90 degree turn). CW to close, CCW to open.

A. VALVE OPEN POSITION

The handle is parallel with the pipeline.

Valves with actuators should be checked for actuator -valve alignment. Misalignment will result in high operational torque and damage to valve stem and seals.

B. VALVE IN CLOSED POSITION

The handle is perpendicular to the pipeline.

3. STEM SEAL ADJUSTMENT:

1. For 1/2" - 2", if slight leakage is noted at stem, straighten lock washer tab, tighten stem nut to flatten Bellville Washers, back stem nut off 1/4 turn, secure lock washer tab.
2. For sizes larger than 2", simply tighten gland bolts evenly until leak stops. Do not over tighten.

4. GENERAL INFORMATION FOR ON-SITE INSTALLATION:

The valve may be fitted in any position on the pipeline.

Before installing the valves, the pipes must be flushed clean of dirt, burrs, and welding residues, or the seats and ball surface will be damaged.

5. DISASSEMBLY & CLEANING PROCEDURES:

CAUTION: Line must be depressurized before disassembly. Valve should be cycled to assure there is no pressure is trapped in valve cavity. Ball valves can trap pressurized media when closed. Flush line with valve 1/2 open to remove hazardous media.

Warning: DONOT remove packing gland or any other valve parts while line is under pressure!



A Subsidiary of Bray International, Inc.

Stem seal leakage may be corrected without disassembly by tightening the packing gland nut until such leakage stops. If the leakage continues or valve operating torque becomes excessive, the seals are worn and replacement will be necessary. If the valve has been used to control hazardous media, it must be decontaminated before disassembly.

It is recommended that the following steps be taken for safe removal and assembly.

As shipped from the factory, Valves contain Silicone based lubricant. This is for break-in and may be removed by disassembly and solvent washing, if it is objectionable for a particular application,

6. DISASSEMBLY FOR STEM AND SEAL REMOVAL:

1. Remove flange connections and lift valve from line for servicing.
NOTE: Care should be taken to avoid scratching or damaging mating faces.
The valve should be adequately supported and in the open position before beginning.
2. Loosen handle set screw and remove handle and stop plate. Next, remove gland nuts, gland flange and gland.
3. Remove body end cap screws, using proper wrench size. Lift off body end. One seat should come out with body end.
4. Repeat the removal procedure for the other flange end. Take out other seat.
5. To remove the ball, rotate the stem so ball is fully closed. Lift the ball from body, using a strap and lift device if necessary. NOTE: Extreme caution should be taken to avoid damage to the ball.
6. The stem must be removed from inside the body - a tap on the top of the stem should loosen it. The thrust washer should come out with the stem. Then remove the stem packing.

7. VISUAL INSPECTION:

Clean and inspect metal parts. It is not necessary to replace the ball and stem unless the seating surfaces have been damaged by abrasion or corrosion. Replacement of all soft parts is strongly recommend whenever the valve is disassembled for reconditioning. This is the surest protection against subsequent leakage after valve assembly. The replacement parts can be ordered in kit form.

NOTE: The valve may be assembled and operated dry where no lubricants are allowed in the system; however, a light lubrication of mating parts will aid in assembly and reduce initial operating torque. Lubricant used must be compatible with the intended line fluid.

8. ASSEMBLY:

½"-2" VALVE ASSEMBLY PROCEDURES:

Hold the body in a vise firmly enough so it will not move but do not crush it.

Put washer protector (11B) and thrust washer (12) on valve stem (5) and slide the stem into the stem hole in valve body (1);

Slide the stem packing components (14) onto the stem until it is sealed against the bottom of the stem hole;

Put packing protector (11A), then packing gland sleeve (15) onto the stem, and top of the stem packing;

Turn the stem until the stem flat is parallel to the port centerline (so that the ball can fit onto the stem);

Install one seat (4) and two body seals inside an end cap (2), make sure the spherical curvature side of the seat will face the ball;

Install the end cap (2) with cap screws (9) and tighten screws to the values indicated in Table 1.

Rotate the stem to the closed position and install the ball (3) inside the valve body. The stem flats will fit into the slot on top of the ball;

Turn the stem so that the ball is in the open position (the ball will not fall out of the valve);

Install the second seat (4) and two body seals inside the remaining end cap (2), make sure the spherical curvature side of the seat will face the ball;

Install the end cap (2) with cap screws (9) and tighten screws to the values indicated in Table 1.

Put Belleville washer (13) together in series mode (bottom Belleville washer curve facing up, the top Belleville washer curve facing down), and then place them onto the stem, on top of the packing gland sleeve;

Put tab washer (19) on top of the Belleville washer and tighten the stem gland nut (26) onto the stem to the required stem gland nut torque value as specified in the chart. (Note: The use of a bore alignment tool, about 1.0



A Subsidiary of Bray International, Inc.

mm [0.04 inch] less than the internal diameter of the end cap and ball, inserted through the end cap and ball will prevent the ball from turning as the stem gland nut is lightened on the stem.

Material for the bore alignment tool should be made from a material softer than 300 Series S.S. so that it will not inadvertently scratch the valve end cap or ball. Suggested materials: aluminum T6061. Acetal or other suitable hard polymer/plastic material.)

Secure the tab washer with one ear bending up; Place the handle (25) onto the stem, on top of the stem gland nut (26A);

Secure the handle (25) with the stem lock nut (26).

3"-4" VALVE ASSEMBLY PROCEDURES:

Put washer protector (11B), thrust washer (12) and stem bearing (13) on valve stem (5) and slide the stem into the stem hole on valve body (1):

Slide the stem packing (14) onto the stem until it is seated against the upper bottom of the stem hole;

Put packing protector (11A), then packing gland sleeve (15) onto the stem, on top of the stem packing;

Install packing gland (16) on top of the packing gland sleeve, lightly tighten to secure packing gland with packing gland bolt (17).

Install stop housing (20), secure stop housing with housing bolts (21) hand tight. Install travel stop (22) and snap ring (30):

Install one seat (4) and two body seals inside an end cap (2), make sure the spherical curvature side of the seat will face the ball;

Install the end cap (2) with cap screws (9) and tighten screws to the values indicated in Table 1.

Turn the stem to the closed position (wrench flats on stem perpendicular to pipeline);

Install the ball (3) inside the valve body. The stem flats will fit into the slot on top of the ball;

Turn the stem so that the ball is in the open position (the ball will not fall out of the valve);

Install the second seat (4) and two body seals inside the remaining end cap (2), make sure the spherical curvature side of the seat will face the ball;

Install the end cap (2) with cap screws (9) and tighten screws to the values indicated in Table 1.

Cycle the valve slowly several times. By cycling slowly, the seats will conform to the ball. A fast turning motion initially may damage the seats before they have a chance to form the proper seal:

Tighten the packing gland bolts (17) gradually until there is no leakage through the packing. Over-tightening can result in excess torque and accelerated wear.

Install handle (25) on to the valve stem and secure the handle with handle bolt (27).

Table 1; Tightening torques for end cap screws

VALVE SIZE	1/2"	3/4"	1"	1 -1/4"	1-1/2"	2"	3"	4"
Bolt Torque (lb-in)	140	210	210	550	550	550	996	996

A Subsidiary of Bray International, Inc.

ITEM	PART NAME
1	BODY
2	END CAP
3	BALL
4	SEAT
5	STEM
6A*	BODY GASKET
6B*	BODY GASKET
9	BODY SCREW
10	ANT-STATIC
11A*	PACKING PROTECTOR
11B*	WASHER PROTECTOR
12	THRUST WASHER
14*	STEM PACKING
15	PACKING GLAND SLEEVE
18	BELLEVILLE WASHER
19	LOCK WASHER
23	STOP SET SLEEVE
24	STOP BOLT
25	LEVER
26	LEVER NUT
28	PLASTIC COVER
29	LOCK MECHANISM

* Items contained in repair kit.

VALVE SIZES:
 1/4" THROUGH 2-1/2"

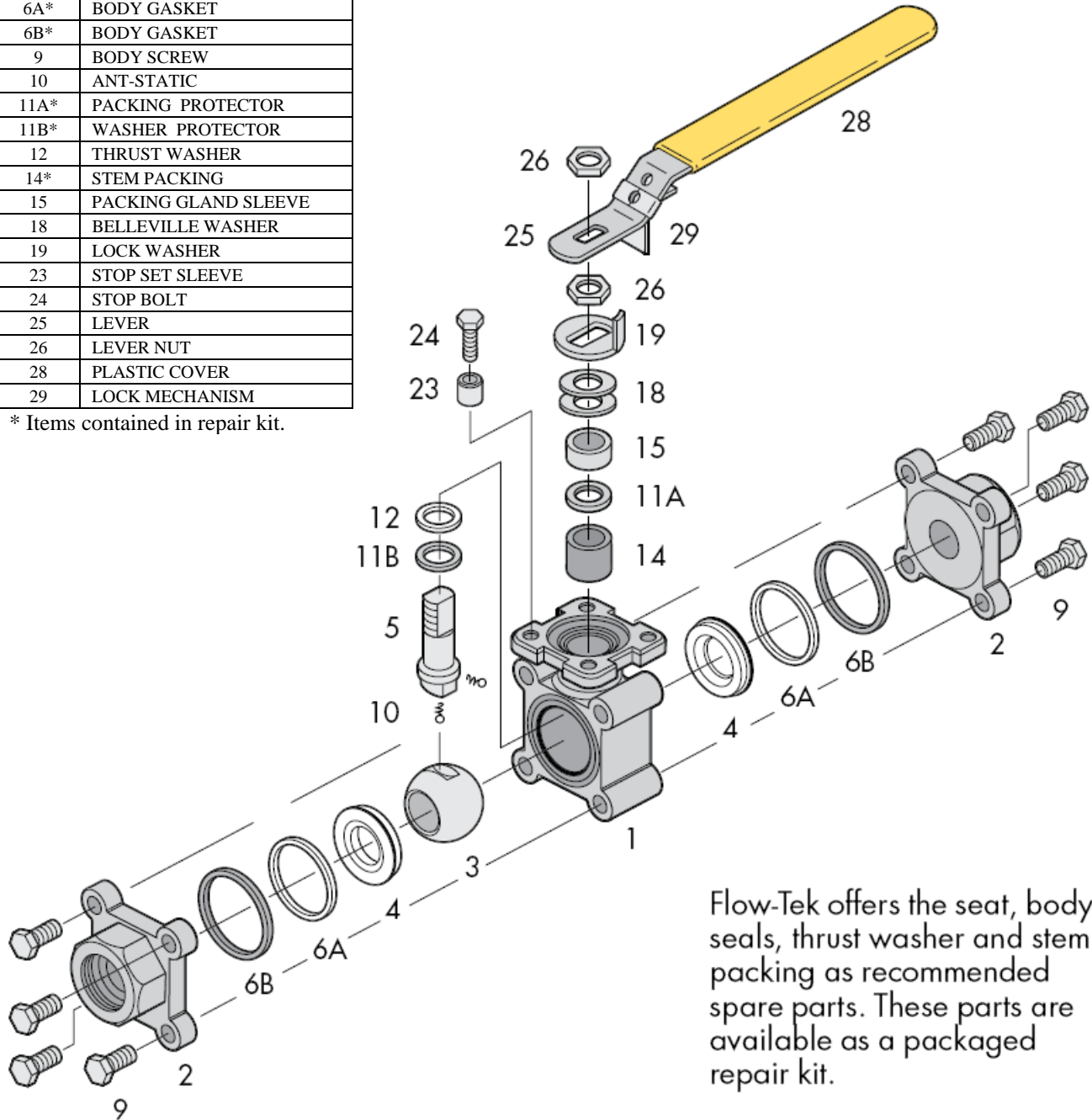

Flow-Tek offers the seat, body seals, thrust washer and stem packing as recommended spare parts. These parts are available as a packaged repair kit.

A Subsidiary of Bray International, Inc.

VALVE SIZES: 3" AND 4"

ITEM	PART NAME
1	BODY
2	END CAP
3	BALL
4	SEAT
5	STEM
6A*	BODY GASKET
6B*	BODY GASKET
9	BODY SCREW
10	ANT-STATIC
11A*	PACKING PROTECTOR
11B*	WASHER PROTECTOR
12	THRUST WASHER
13	STEM BEARING
14*	STEM PACKING
15	PACKING GLAND
16	PACKING FOLLOWER
17	GLAND BOLT
20	STOP HOUSING
21	HOUSING BOLT
22	TRAVEL STOP
25A	HANDLE
25B	HANDLE JUNCTION
27	HANDLE BOLT
30	SNAP RING

* Items contained in repair kit.

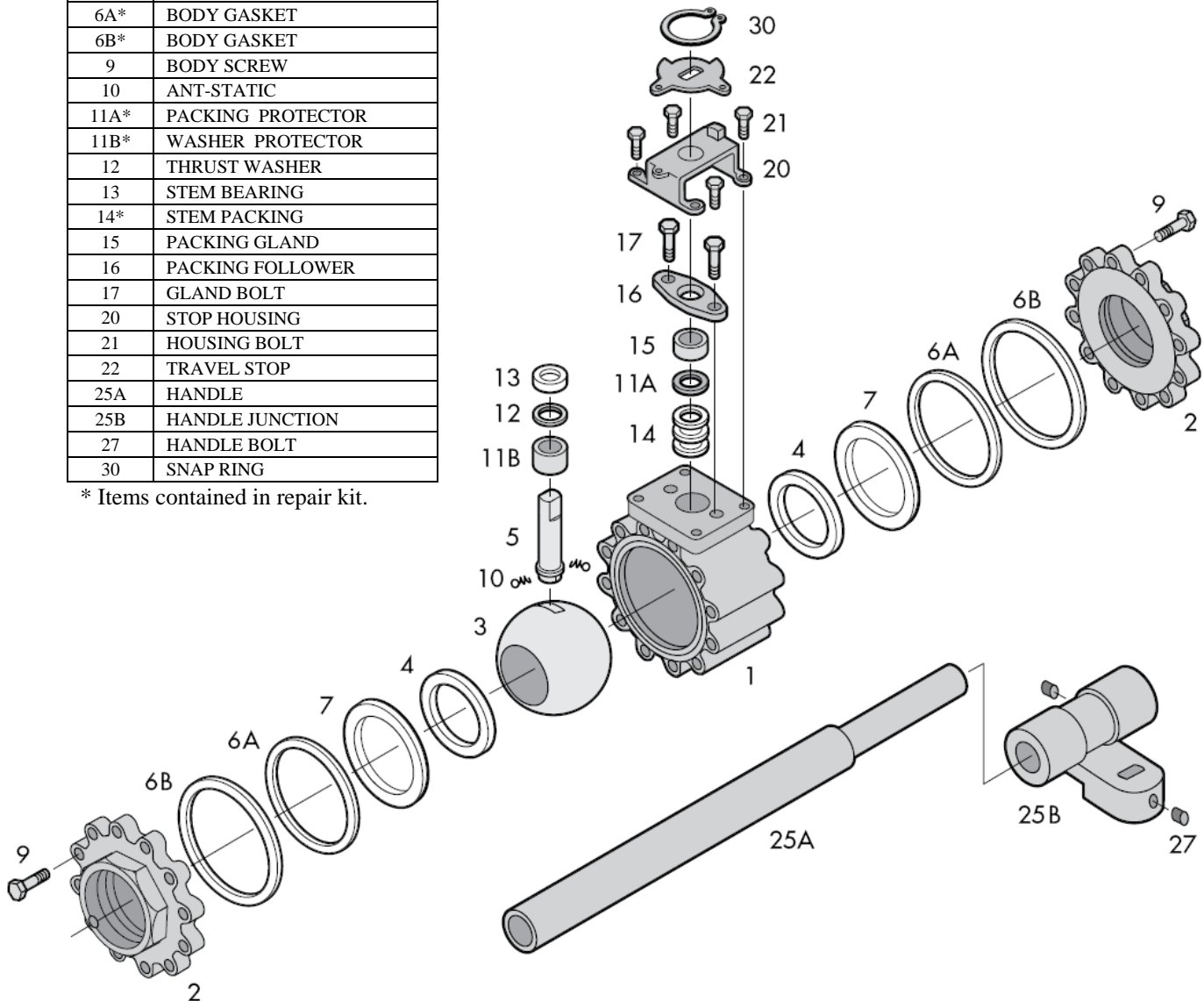



8323 N. Eldridge Pkwy, #100, Houston, Texas 77041

Tel: 832-912-2300; Fax: 832-912-2301

Website: <http://www.flow-tek.com>

A Subsidiary of Bray International, Inc.

9. INSTALLATION OF THREADED VALVES

Valve can be screwed on without the use of union or with the end caps removed from the body.

The use of a thread sealant is recommended;

Apply wrench only on the valve end being tightened. Do not tighten by applying torque to the opposite end cap or other valve component. Tightening by using the valve body, handle or the opposite end cap can seriously damage the valve; Use a wrench on both the second end cap and pipe to avoid applying torque to the body through the bolting.

In some applications, screwed valves may be back-welded. Disassemble as per instructions for weld end valves. Confirm that the end cap bolt holes are aligned with the body screw holes on both ends and that the end caps are parallel and correctly spaced to fit the valve body before re-assembly or back welding.

Do not use the body screws to pull the pipe ends together or into alignment.

10. INSTALLATION OF EXTENDED WELD END VALVE

Insure that appropriate weld procedures are implemented that are compatible with the materials used.

Butt weld valves with 3 inch or longer extended weld ends do not require disassembly for installation welding.

Simply ensure that ball is in the full open position, and perform normal welding procedures, using care that the valve body does not reach a temperature above 200F.

11. INSTALLATION OF WELD-ENDVALVES (FPISP2000, FPISP3000 Series)

Insure that appropriate weld procedures are implemented that are compatible with the materials used.

Tack weld the valve to the pipe at four points on both end caps.

With the valve in open position, (the valve is in the open position when the handle is parallel to the axis of the valve and pipe), loosen all body bolts, take the body out.

Turn the handle in the half open position to assist in the removal of the seats and body gaskets.

Turn handle in closed position and remove ball.

Place all removed parts in a clean and secure place.

Replace the body and all bolts and tighten them slightly. This operation is very important, so that the body and end caps remain perfectly parallel, thus preventing any leakage at the body joint after welding.

Finish welding both end caps onto the pipe.

When cool, clean end caps, turn valve to closed position and replace ball. Turn valve in open position and replace seats and body gaskets.

Place body between the two end connections; then replace all bolts and tighten firmly

(See table 1. Tightening torques for end cap screws).



A Subsidiary of Bray International, Inc.

12. Short and Long Term Storage:

Short term:

1. Short term storage is defined as storage of products and equipment to be used in the construction of a project for periods of one to three months.
2. Ball valves should remain in the original shipping containers be placed on pallets of wood or other suitable materials. End protectors should remain on the valve ends to prevent the entrance of dirt.
3. Valves should be stored in the open position to protect the ball and seats.
4. Storage of ball valves can be in an open uncovered area provided provisions are made for inclement weather such as tarps or sheeting. Valves with electric actuators shall be stored under cover until ready for installation.

Long term:

1. Long term storage is storage of products and/or equipment for periods of three months or more.
2. Valves should be stored in the open position to protect the ball and seats.
3. Ball valves should remain in the original shipping containers placed on pallets of wood or other suitable materials and stored indoors. End protectors should remain on the valve ends to prevent the entrance of dirt. The storage environment should be dry and not have severe swings in temperature and humidity.

13. Safety Summary

1. Read completely and understand all instructions provided prior to beginning installation or maintenance.
2. Follow all instructions as described using the correct tools for the job.
3. Before installing this equipment, confirm that it is suitable for the intended service.
The identifications tags describe the maximum allowable service conditions for this product.
4. Be sure that the installation is protected by appropriate pressure control and safety devices to ensure that acceptable limits are not exceeded.
5. Confirm that line pressure has been removed and that there is no pressure trapped within the valve prior to beginning service. Do not attempt to remove any packing components or other fittings before confirming that pressure has been completely removed!
6. Do not begin service work without proper tools and protective safety measures.
7. The work area should be clear of obstructions and other safety hazards.